



Applications

- Signature Recognition
 - Biologicals
 - Chemicals
- Microwave and THz Spectroscopy
- Materials Characterization

Features

- Full Turnkey System: Arrives Configured and Ready to Start Making Measurements
- Fringe-free operation: The patented phase modulation and detection method effectively removes fringes from the data
- Portable: can operate on a 19V external battery pack (not included).
- Compact: Only 20 cm x 20 cm x 6 cm (8"x 8" x 2.5") and Less than 5 kg with case
- Continuous Rapid Scanning with 1 THz of bandwidth
- Fiber Optic Coupled THz Source and Detector Heads
- Room Temperature Solid State Detection: No Cryogenics Required
- Shipped in a rugged carrying case for shipping ease.

Fringe-Free Frequency Domain Terahertz Spectroscopy

The Bakman Technologies' PB7300 series of spectrometers are ideal for THz researchers and application developers who need to study the properties of materials at THz frequencies with high-resolution, but who don't want to design and build their own high-resolution THz spectroscopy system. The PB7300-1000-FF can sweep from 1 THz to 2 THz in a single scan with frequency resolution better than 0.25 GHz.¹

The PB7300-1000-FF employs precisely tuned, fiber coupled, butterfly packaged semiconductor DFB lasers, an advanced photo-mixing source and detector, a Lithium Niobate phase modulator and sophisticated digital control hardware and software to provide a fully turnkey THz spectrometer. The room temperature solid-state homodyne detection technique eliminates the need for cryogenics while detecting and summing the first and second harmonics of the phase modulation allows the removal of that pesky fringe pattern that arises due to coherent detection. The highly efficient CW nature of the photo-mixing source puts all the THz power at the frequency of interest, yielding excellent signal-to-noise ratios across the scan range of up to 70 dB Hz. Further, the first and second harmonic fringe data is saved so that it may be employed to measure phase shifts imparted by the sample.

Unlike time-domain systems requiring expensive mode-locked lasers, the tunable semiconductor laser diodes in the PB7300 can support linear scans or can 'frequency hop' between frequencies of interest to scan specific regions of the spectrum with varying degrees of resolution. The fiber-optically-coupled source and detector heads are mounted on a rail system and configured for transmission measurements. They may also be detached from the processor unit and used with extended fiber optic cables to provide maximum measurement flexibility in a wide range of applications.

Performance Highlights

Parameter	Min	Typical	Max	Units
System Bandwidth	900	1100	1400	GHz
Spectral Purity	0.005	0.010	0.015	GHz
Frequency Resolution	100	1000	5000	MHz
Dynamic Range @ 100 GHz	60	65	75	dB Hz
Dynamic Range @ 1000 GHz	45	50	55	dB Hz
Dynamic Range @ 1400 GHz	35	40	45	dB Hz
THz Beam Diameter @ 500 GHz		12		mm (FWHM)
THz path length	10	25		cm
Tuning speed		10	100	GHz/sec
Phase Modulation Frequency		6000		Hz

¹ Other frequencies are available but tuning bandwidth is limited to approximately 1.1 THz

Terahertz Performance

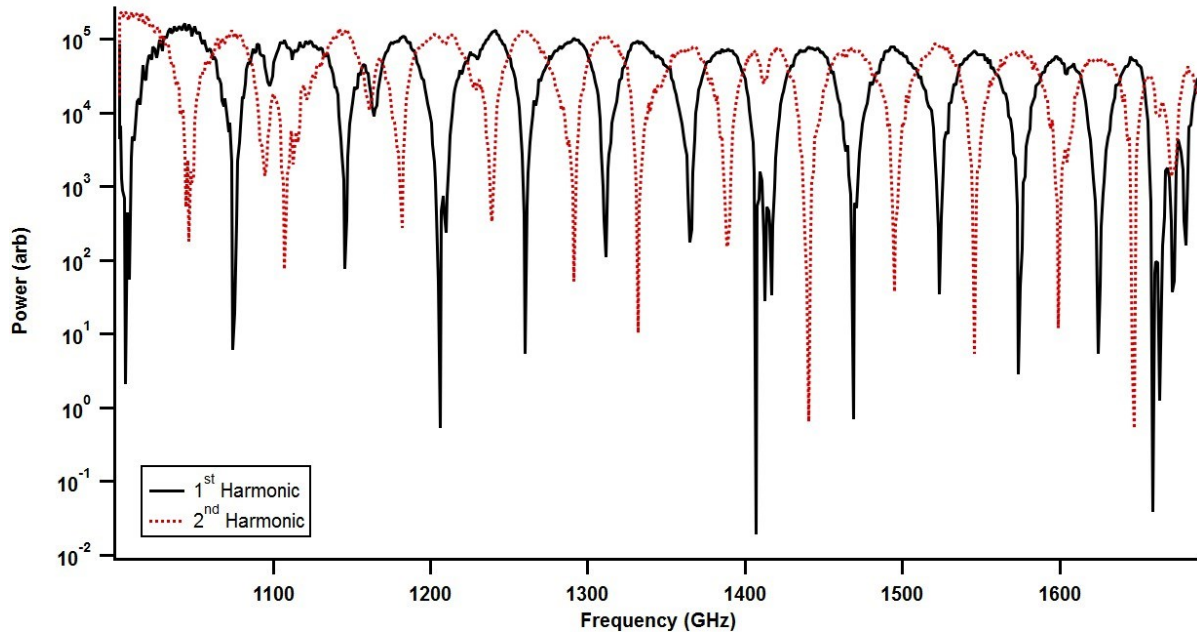

The figure (above) illustrates a single scan of laboratory air without any processing (smoothing) or averaging. The phase modulation technique allows the detection of the first and second harmonics as shown in the plot above: summing the harmonics results in the fringe free spectrum shown below. No secondary processing was performed on the data.

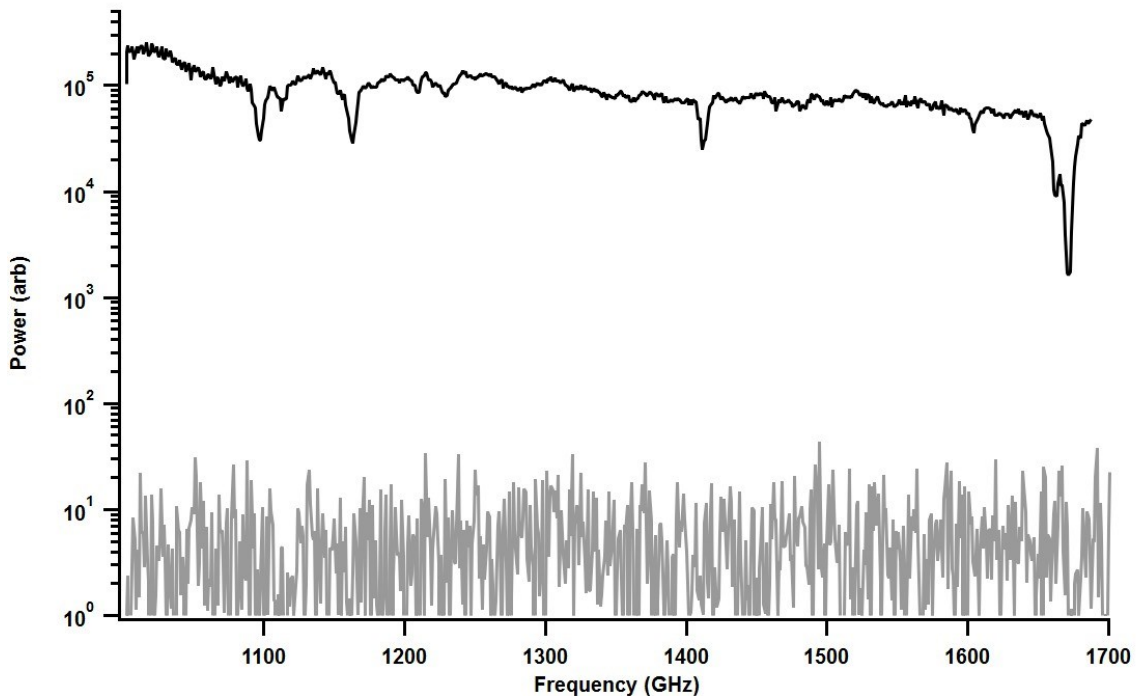

PB7300-1000-FF Frequency Domain Terahertz Spectrometer (Fringe-Free)



DATASHEET | JUNE 2023

TERAHERTZ SYSTEMS

PB7300-1000-FF Terahertz System ²



PB7220 2000-T Terahertz Optics

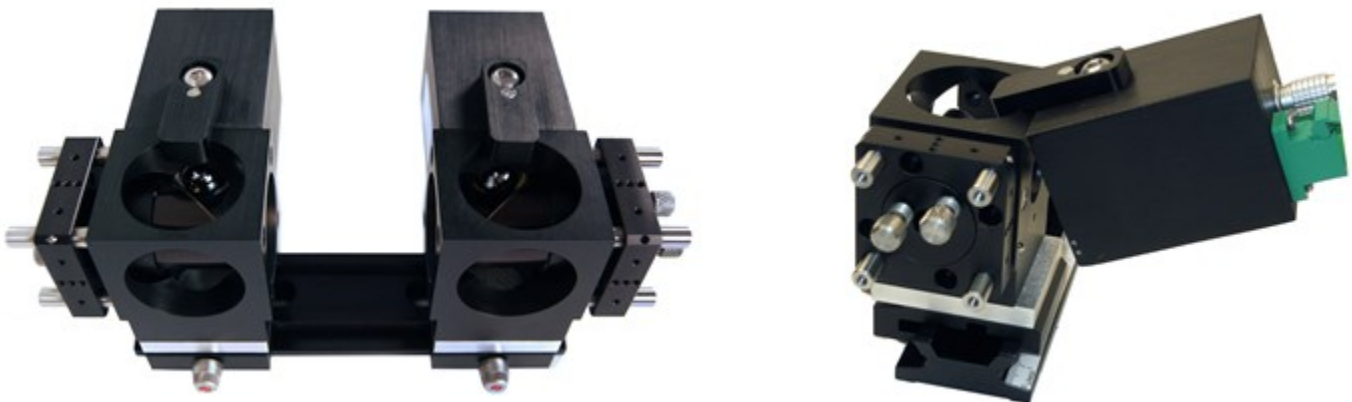

² The PB7300-1000-FF is also available in a 19" rack unit.

Terahertz Control Unit Dimensions

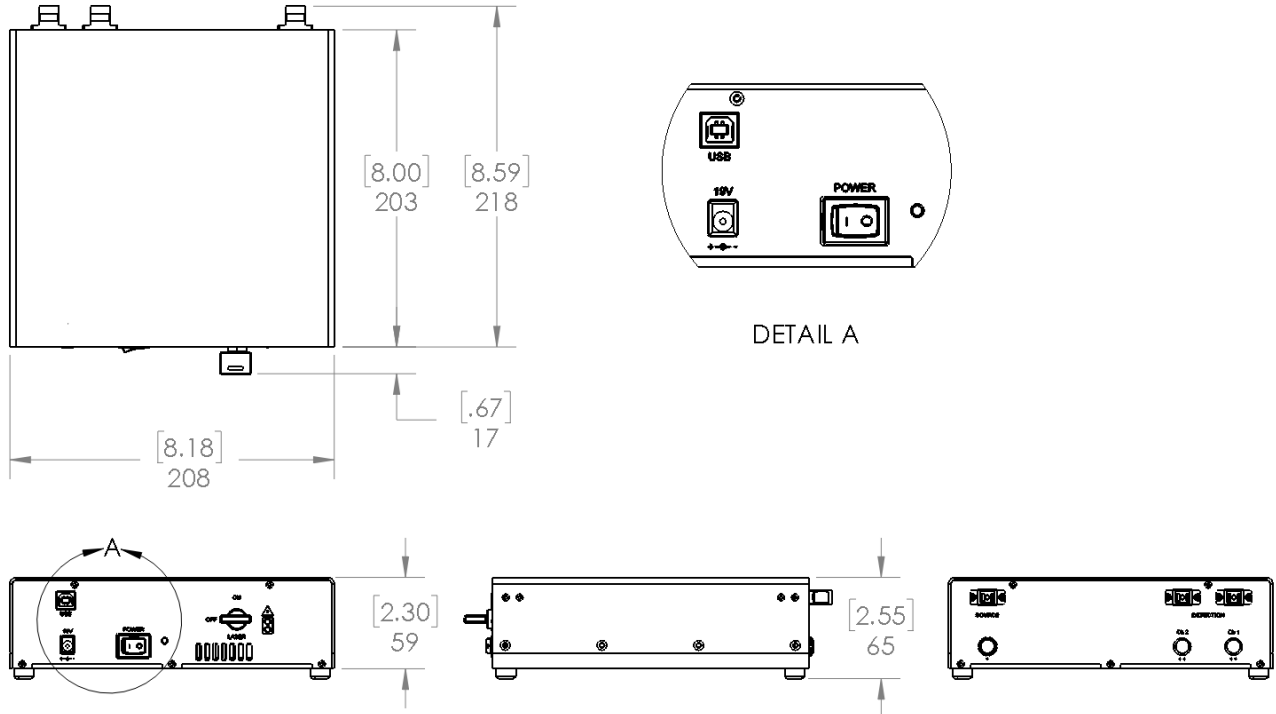

Terahertz Optics Dimensions

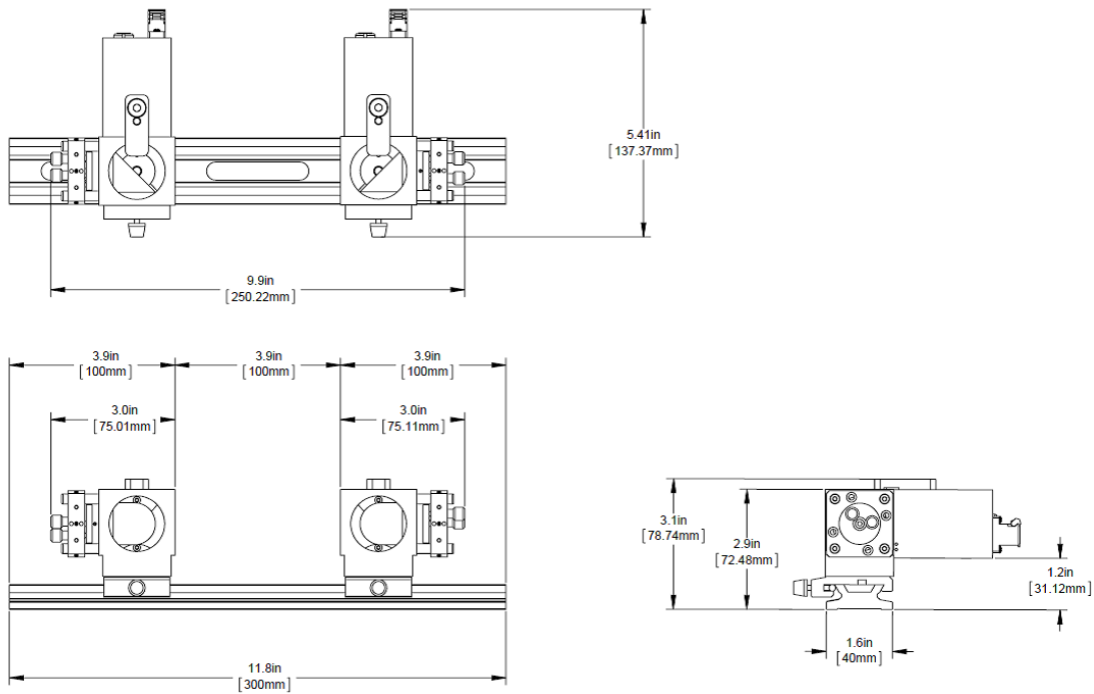

Graphical User Interface

The PB7300 includes highly functional software for Windows 10 PCs. Besides being able to control the frequency of the system with the Dwell or Scan, it is also possible to do averaging, background subtraction, normalization and smoothing all from the same interface. The calibration files are installed into the PB7300, and if a new computer is connected to the PB7300, the calibration files are automatically downloaded to the computer. This makes it easy to move the PB7300 to different computers.

Single-Channel System Graphical User Interface

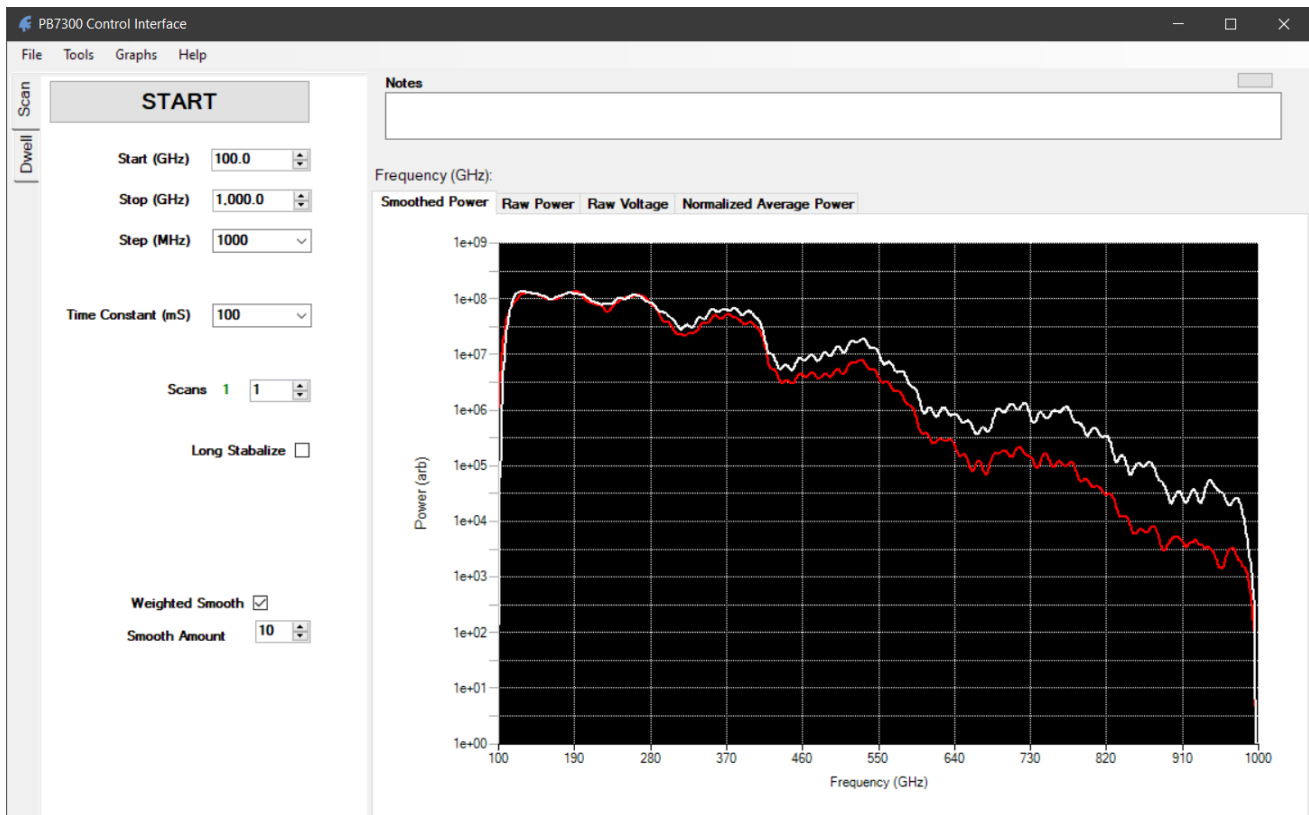

Custom Programming Interface

For customers who would like to design their own interface or incorporate the PB7300 into their own custom software, Bakman Technologies can provide a Python interface.

Specifications

Parameter	Value
Weight – Control Chassis (ea)	1.8 kg
Weight – Adaptable Optical Bench with Heads and Optics	2.5 kg
Operating Temperature	-20°C to +55°C
Storage Temperature	-20°C to +75°C
Humidity	10% to 90% (non-condensing)
Input Voltage (AC/DC Adapter)	100 – 240 VAC
Input Frequency	50 - 60 Hz
Input Voltage (DC Direct/Battery)	15 - 19 V
Maximum Power Consumption @ 25C	10 W

Contact Information

USA (HEADQUARTERS)	EUROPE
Dr. Joseph R. Demers Bakman Technologies E: sales@bakmantechologies.com www.bakmantechologies.com	Dr. Frank Kubacki EQ Photonics E: fkubacki@eqphotonics.de www.eqphotonics.de